

## Active DST module DST-2

# Breathe new smart digital life into your old or new transducers, with this NMEA depth, speed & temperature digital signal processor ...

The Actisense™ Active Depth/Speed/Temperature module is the best solution for interfacing standard analogue transducers and NMEA 0183 compatible chart plotters, radars, and on board laptop PCs.

Designed for use with most existing analogue transducers already fitted to a vessel, or new analogue transducers. Our industry proven depth sounder algorithm has the best-in-class seabed tracking, and when in conjunction with a good quality depth transducer, can track the seabed down to 0.3m or 1 foot (proven with Airmar transducers).

100W peak depth power enables a maximum depth range of 100m or 330 feet under optimum conditions (proven with Airmar transducers).

The DST module's data interface is configured for NMEA 0183 and RS232, but

can operate as a fully bidirectional RS485 interface for customised applications, such as a multiple depth sounder network.

150 KHz & 200 KHz depth transducer frequencies are available to match most existing transducers. For enhanced interference rejection, a 235 KHz capable module is also available.

Log transducer and temperature thermistor interfaces allow additional data to be provided over the NMEA data stream, giving a cable saving when those extra measurements are required.

Easy reprogramming of the DST module is possible using free software available on the Actisense™ website. The DST module's software can be updated with the very latest software enhancements, or special purpose software such as a fish-finder/hydrograph software upgrade.

The DST module can be further enhanced with the Actisense™ NMEA display software for Windows™. This software displays the depth, speed, trip distance and temperature values, and plots a historical graph for each value. Available from the Actisense™ website.

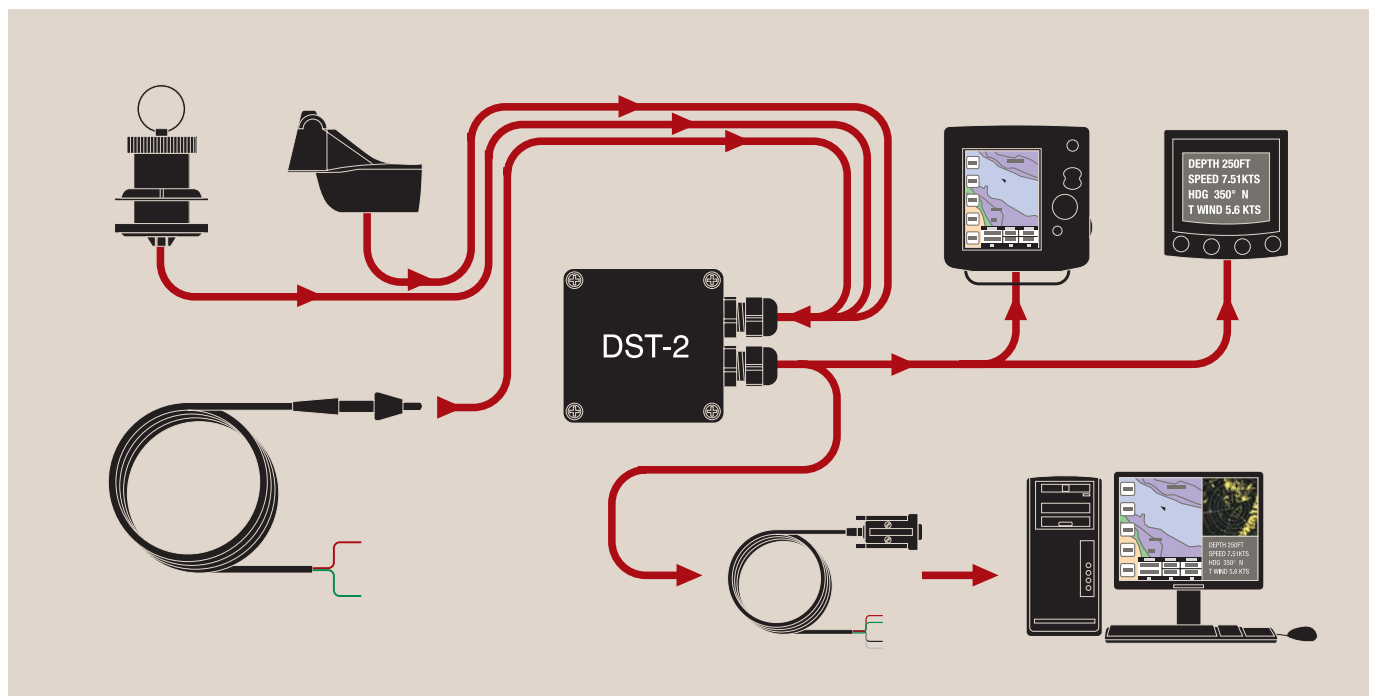

# Active DST module DST-2

## Specifications

### NMEA / RS485 Output system

- Exceeds all NMEA 0183 output voltage specifications
- Capable of driving up to 8 NMEA 0183 compliant devices
- Short circuit protected
- Static discharge protected
- Standard 4800 NMEA Baud rate. Other Baud rates up to 38400 are possible for customised software designs

### RS485 Input System

- Exceeds all NMEA 0183 input voltage specifications
- Standard RS485 input voltage specifications

### Data Output rate

- Depth, Speed, Trip and Temperature data output once per second once the respective transducer has been detected
- Customised output rates are available

### Processing specifications

- Depth: Minimum and maximum dependent on transducer.

Narrow beam transducers, like the Airmar P66 transom-mount:

0–10 knots: Minimum 0.3m, Maximum 200m

10–40 knots: Minimum 0.3m, Maximum 100m

Wide beam transducers, like the Airmar DT800 through-hull:

0–10 knots: Minimum 0.3m, Maximum 150m

10–40 knots: Minimum 0.3m, Maximum 100m

- Speed: Minimum and maximum dependent on transducer. Airmar standard paddle-wheel log transducer allows 0.5 – 50 knots
- Temperature: Minimum and maximum dependent on transducer. Uses an industry standard thermistor (10 KΩ at 25°C).

### Depth frequencies

- Transducer drive frequency of 150 KHz, 200 KHz, or 235 KHz

### Power supply

- Supply Voltage range: 10 to 28 volts DC
- Power Consumption: 40 mA @ 12v DC / 480 mW

### Environmental

- Recommended operating temperature: -20°C to +70°C
- Casing provided with sealing grommets to IP66

### General

- Weight: 200 grams
- Dimensions: see diagram
- Guarantee: 2 years

### Built-in Firmware / Software

- Free software updates available on Actisense™ website
- Simple one button reprogramming utility
- Future-proof design
- Custom programming service is available

### Triducer Display Software

- Freely available on Actisense™ website
- Windows™ PC software (98/ME and NT/2000/XP)
- Displays the depth, speed, trip and temperature data received from the DST module in both digital and historical graph form

### Part numbers

- 150 KHz module: DST-2-A-150
- 200 KHz module: DST-2-A-200
- 235 KHz module: DST-2-A-235

## Dimensions

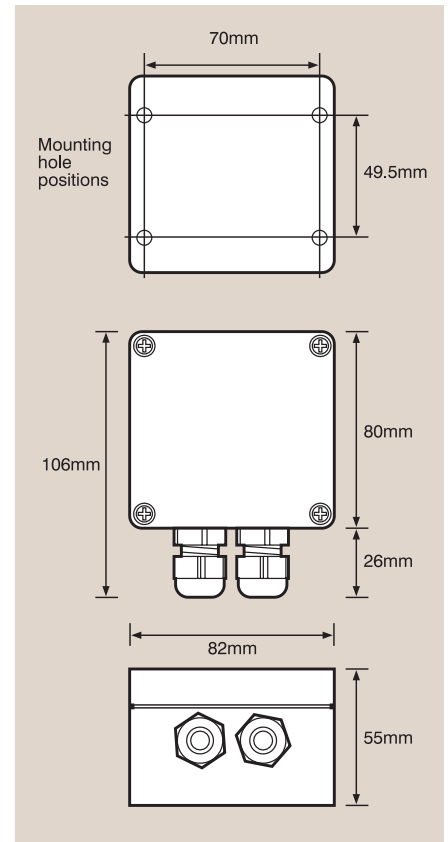

### Maahantuojat:

Promarine Oy  
Verkaranta 1A3-4  
FIN-20660 Littoinen

e: myynti@promarine.fi  
www.promarine.fi

Active Research Limited  
Unit 5, Wessex Trade Centre  
Ringwood Road, Poole  
Dorset UK BH12 3PF

t:+44 (0)1202 746682  
f:+44 (0)1202 746683  
e: sales@actisense.com  
www.actisense.com